

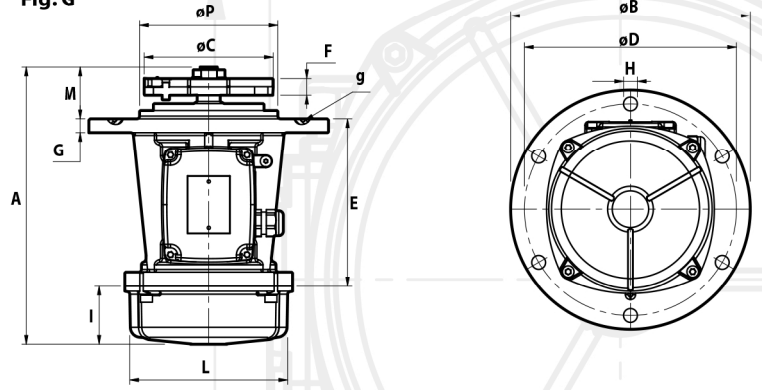

2 poles - 3000/3600 rpm

Description				Mechanical specifications		Electrical specifications											
Code	Type	SIZE	SFA	I2D Temp. class	Centrifugal force (A/B)*				Weight		Max input power		Max. current		Ia/In		
					kg	60 Hz	50 Hz	60 Hz	kg	60 Hz	50 Hz	60 Hz	400 V 50 Hz	460 V 60 Hz	50 Hz	60 Hz	
three-phase	600375	MTF 3/65-S02	00	-	120°C	31/31	44/44	0.30/0.30	0.43/0.43	5.40	5.40	120	120	0.27	0.23	3.43	3.90
	600369	MTF 3/200-S02	01	•	120°C	106/75	109/109	1.04/0.74	1.07/1.07	7.50	7.30	180	180	0.35	0.30	2.68	3.00
	600370	MTF 3/300-S02	10	•	120°C	151/103	148/148	1.48/1.01	1.45/1.45	11.2	10.9	260	270	0.60	0.50	3.47	4.20
	600378	MTF 3/500-S02	20	•	120°C	251/163	235/235	2.46/1.60	2.30/2.30	15.0	14.1	450	500	0.80	0.75	4.21	4.80
	600456	MTF 3/650-S02	20	•	120°C	393/251	377/235	3.85/2.46	3.70/2.30	15.2	14.3	450	500	0.80	0.75	4.21	4.80
	600380	MTF 3/800-S02	30	•	120°C	393/262	377/377	3.85/2.57	3.70/3.70	17.0	16.5	650	685	1.10	1.00	3.83	6.00
	600285	MTF 3/1100-S90 Δ	40	-	120°C	590/590	566/566	5.79/5.79	5.55/5.55	26.0	25.0	940	1130	1.70	1.60	6.79	7.00
single-phase	600375	MTF 3/65-S02	00	-	120°C	31/31	44/44	0.30/0.30	0.43/0.43	5.40	5.40	110	110	0.56	1.52	2.24	2.24
	600369	MTF 3/200-S02	01	-	120°C	106/75	109/109	1.04/0.74	1.07/1.07	7.50	7.30	165	165	0.75	1.52	1.67	2.24
	600370	MTF 3/300-S02	10	-	120°C	151/103	148/148	1.48/1.01	1.45/1.45	11.2	10.9	280	280	1.25	2.40	2.48	3.52
	600378	MTF 3/500-S02	20	-	120°C	251/163	235/235	2.46/1.60	2.30/2.30	15.0	14.1	500	500	2.30	4.50	3.35	4.22
	600456	MTF 3/650-S02	20	-	120°C	393/251	377/235	3.85/2.46	3.70/2.30	15.2	14.3	500	500	2.30	4.50	3.35	4.22
	600380	MTF 3/800-S02	30	-	120°C	393/262	377/377	3.70/2.57	5.55/5.55	17.0	16.5	700	750	3.25	7.00	4.00	4.14

Fig. G



Dimensional specifications (mm)

Type	Fig.	A	øB	øC	Holes			E	F	G	I	L	M	øP	Capacitor (µF)		Cable entry thread	Seal g
					øD	øH	N°								220 V 50 Hz	115 V 60 Hz		
MTF 3/65-S02	G	189	130	86	109	8.5	4	132	7.5	10	36	96	22	-	-	-	M20x1,5	OR 3350
MTF 3/200-S02	G	225.5	211.5	92	188	12	4	144	21 (50Hz) 15 (60Hz)	10	58	103	23.5	-	-	-	M20x1,5	OR 4650
MTF 3/300-S02	G	247	215	110	187	12	4	179.5	18 (50Hz) 12 (60Hz)	13	54	127	13.5	-	-	-	M20x1,5	OR 4625
MTF 3/500-S02	G	279.5	245	122	205	12	6	124	24 (50Hz) 15 (60Hz)	12	65	145	90.5	162	-	-	M25x1,5	OR 4700
MTF 3/650-S02	G	279.5	245	150 (60Hz) 132 (60Hz)	205	12	6	124	18	12	65	145	90.5	162	-	-	M25x1,5	OR 4700
MTF 3/800-S02	G	301	260	150 (60Hz) 132 (60Hz)	230	15	6	182	18	15	63	170	56	150	-	-	M25x1,5	OR 4800
MTF 3/1100-S90 Δ	G	383	279	145	254	14	4	-	31 (50Hz) 21 (60Hz)	17.5	57.5	-	63	229	-	-	M25x1,5	-
MTF 3/65-S02	G	189	130	86	109	8.5	4	132	7.5	10	36	96	22	-	10	28	M20x1,5	OR 3350
MTF 3/200-S02	G	225.5	211.5	92	188	12	4	144	21 (50Hz) 15 (60Hz)	10	58	103	23.5	-	10	28	M20x1,5	OR 4650
MTF 3/300-S02	G	247	215	110	187	12	4	179.5	18 (50Hz) 12 (60Hz)	13	54	127	13.5	-	16	25	M20x1,5	OR 4625
MTF 3/500-S02	G	279.5	245	122	205	12	6	124	24 (50Hz) 15 (60Hz)	12	65	145	90.5	162	12.5	50	M25x1,5	OR 4700
MTF 3/650-S02	G	279.5	245	150 (60Hz) 132 (60Hz)	205	12	6	124	18	12	65	145	90.5	162	12.5	50	M25x1,5	OR 4700
MTF 3/800-S02	G	301	260	150 (60Hz) 132 (60Hz)	230	15	6	182	18	15	63	170	56	150	25	90	M25x1,5	OR 4800



4 poles - 1500/1800 rpm

Description		Mechanical specifications								Electrical specifications							
Code	Type	SIZE	SFA	I12D Temp. class	Centrifugal force (A/B)*				Weight		Max input power		Max. current		I _a /I _m		
					kg	60 Hz	50 Hz	60 Hz	50 Hz	60 Hz	50 Hz	60 Hz	400 V 50 Hz	460 V 60 Hz	50 Hz	60 Hz	
three-phase	601446	MTF 15/80-S02	01	•	120°C	39/39	38/38	0.38/0.38	0.37/0.37	6.8	6.5	85	95	0.21	0.20	1.78	1.95
	601403	MTF 15/200-S02	10	•	120°C	106/74	107/107	1.04/0.72	1.05/1.05	14.0	13.2	170	170	0.41	0.40	2.34	2.75
	601405	MTF 15/400-S02	20	•	120°C	205/142	205/205	2.01/1.39	2.01/2.01	20.6	19.8	300	350	0.60	0.60	3.33	3.50
	601406	MTF 15/550-S02	20	•	120°C	276/205	295/295	2.70/2.01	2.70/2.70	22.0	20.6	300	350	0.60	0.60	3.33	3.50
	601407	MTF 15/700-S02	30	•	120°C	360/263	380/380	3.53/2.58	3.73/3.73	26.0	24.5	525	665	0.92	0.98	3.48	3.43
	601280	MTF 15/1100-S90 Δ	40		120°C	522/522	491/491	5.12/5.12	4.82/4.82	36.0	31.4	900	1050	1.45	1.50	4.10	4.20
	601379	MTF 15/1710-S02-VRS	50	-	150°C	894/322	878/355	8.77/3.16	8.61/3.48	44.0	41.5	1100	1200	2.00	1.90	4.29	4.89
	601380	MTF 15/2000-S02-VRS	50	-	170°C	1021/357	1017/390	10.0/3.50	9.98/3.83	48.0	45.5	1350	1450	2.50	2.30	4.30	4.90
	601381	MTF 15/3810-S02-VRS	70	-	135°C	1908/707	1872/718	18.7/6.94	18.4/7.04	100	93	2200	2500	3.90	3.90	7.11	6.92
single-phase	601446	MTF 15/80-S02	01	-	120°C	39/39	38/38	0.38/0.38	0.37/0.37	6.8	6.5	90	100	0.43	1.00	1.20	1.30
	601403	MTF 15/200-S02	10	-	120°C	106/74	107/107	1.04/0.72	1.05/1.05	14.0	13.2	210	230	1.00	2.00	1.50	1.85
	601405	MTF 15/400-S02	20	-	120°C	205/142	205/205	2.01/1.39	2.01/2.01	20.6	19.8	240	320	1.20	2.80	2.50	2.50
	601406	MTF 15/550-S02	20	-	120°C	276/205	295/295	2.70/2.01	2.70/2.70	22.0	20.6	240	320	1.20	2.80	2.50	2.50
	601407	MTF 15/700-S02	30	-	120°C	360/263	380/380	3.53/2.58	3.73/3.73	26.0	24.5	450	550	2.15	5.15	5.44	3.63

* Listed as A/B: total centrifugal force is the sum of centrifugal force of top weights (A) and centrifugal force of bottom weights (B).
I_a/I_m = ratio between start-up current and maximum current.

Weight adjustment, see pages 66, 67

Fig. G

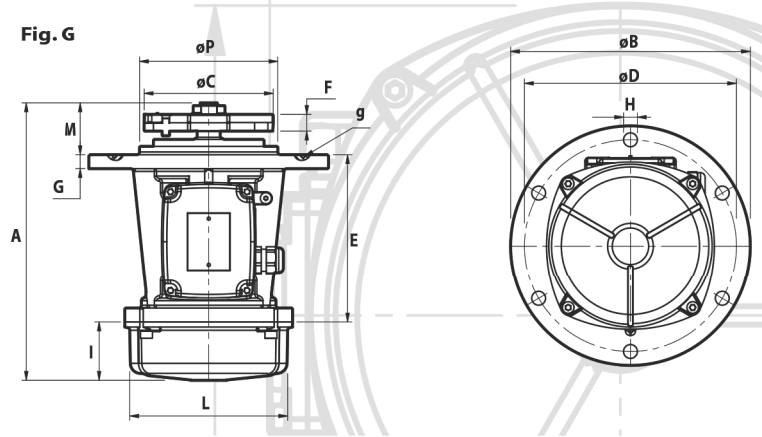

Dimensional specifications (mm)

Type	Fig.	A	øB	øC	Holes			E	F	G	I	L	M	øP	Capacitor (µF)		Cable entry thread	Seal g
					øD	øH	N°								220 V 50 Hz	115 V 60 Hz		
MTF 15/80-S02	G	225.5	211.5	92	188	12	4	144	31 (50Hz) 21 (60Hz)	10	58	103	23.5	-	-	-	M20x1,5	OR 4650
MTF 15/200-S02	G	292.5	215	114 (50Hz) 108 (60Hz)	187	12	4	179.5	48 (50Hz) 40 (60Hz)	13	77	127	36	-	-	-	M20x1,5	OR 4625
MTF 15/400-S02	G	335.5	245	130	205	12	6	124	59 (50Hz) 42 (60Hz)	12	93	145	118.5	162	-	-	M25x1,5	OR 4700
MTF 15/550-S02	G	376.5	245	130	205	12	6	124	79 (50Hz) 59 (60Hz)	12	114	145	138.5	162	-	-	M25x1,5	OR 4700
MTF 15/700-S02	G	380.5	260	154	230	15	6	182	59 (50Hz) 46 (60Hz)	15	106	170	92.5	150	-	-	M25x1,5	OR 4800
MTF 15/1100-S90 Δ	G	426	279	190	254	14	4	-	49	17.5	57.5	-	84.5	229	-	-	M25x1,5	-
MTF 15/1710-S02-VRS	G	488	350	190	290	17	6	232	84 (50Hz) 58 (60Hz)	18	134	209	122	172	-	-	M25x1,5	-
MTF 15/2000-S02-VRS	G	561	350	190	290	17	6	232	96 (50Hz) 66 (60Hz)	18	171	209	158	172	-	-	M25x1,5	-
MTF 15/3810-S02-VRS	G	614	410	250 (50Hz) 244 (60Hz)	350	22	6	310	78 (50Hz) 58 (60Hz)	20	178	280	125.5	234	-	-	M25x1,5	-
MTF 15/80-S02	G	225.5	211.5	92	188	12	4	144	31 (50Hz) 21 (60Hz)	10	58	103	23.5	-	3.15	25	M20x1,5	OR 4650
MTF 15/200-S02	G	292.5	215	114 (50Hz) 108 (60Hz)	187	12	4	179.5	48 (50Hz) 40 (60Hz)	13	77	127	36	-	5	25	M20x1,5	OR 4625
MTF 15/400-S02	G	335.5	245	130	205	12	6	130	59 (50Hz) 42 (60Hz)	12	93	145	118.5	162	32/12 ○	35	M20x1,5	OR 4700
MTF 15/550-S02	G	376.5	245	130	205	12	6	130	79 (50Hz) 59 (60Hz)	12	114	145	138.5	162	32/12 ○	40/35 ○	M20x1,5	OR 4700
MTF 15/700-S02	G	380.5	260	154	230	15	6	182	59 (50Hz) 46 (60Hz)	15	106	170	92.5	150	96/16 ○	160/40 ○	M25x1,5	OR 4800

Δ Supplied without weight covers on both sides ○ Start-up capacitor / Running capacitor.