

# MVB/MVB-FLC



CESI KCI

Ex KCI



## MVB 4 poles - 1500/1800 rpm

	Description					Mechanical specifications				Electrical specifications				
	Code	Type	SIZE	SF	Ex II2D Temp. class	Centrifugal force				Weight kg	Max input power W		Max. current A	
						50 Hz kg	60 Hz kg	50 Hz kN	60 Hz kN		50 Hz	60 Hz	400 V 50 Hz	460 V 60 Hz
three-phase	601226	MVB 1510/15	50	•	150°C	1500	1500	14.7	14.7	41.5	1100	1200	2.10	2.00
	601129	MVB 2500/15	60	•	/	2500	2500	24.5	24.5	67.0	2150	2700	3.90	4.10
	601130	MVB 4500/15	80	•	/	4500	4500	44.1	44.1	106	4000	4200	6.70	5.80
	601131	MVB 7000/15	90	•	/	7000	7000	68.7	68.7	160	7000	7000	11.8	10.2

## Versions

Version A

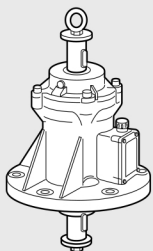

Basic model.

Version B

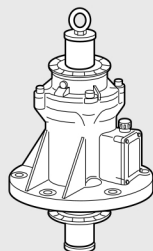

Basic model with angle disc.

Version C

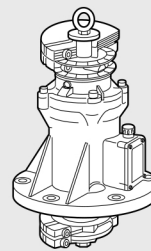

Basic model with angle disc and weights type C (clamped).

Version D

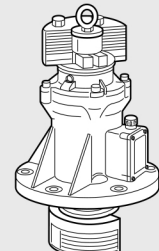

Basic model with angle disc and weights type D (lamellar).

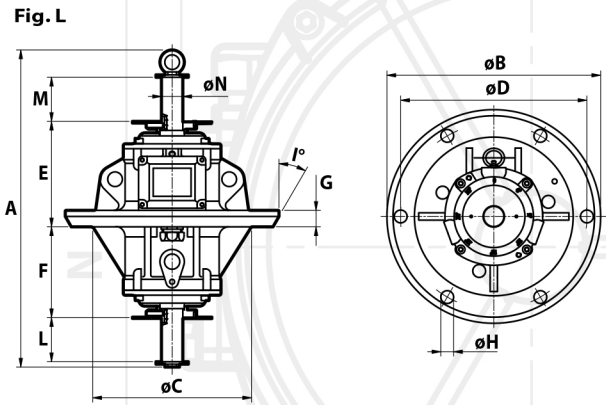
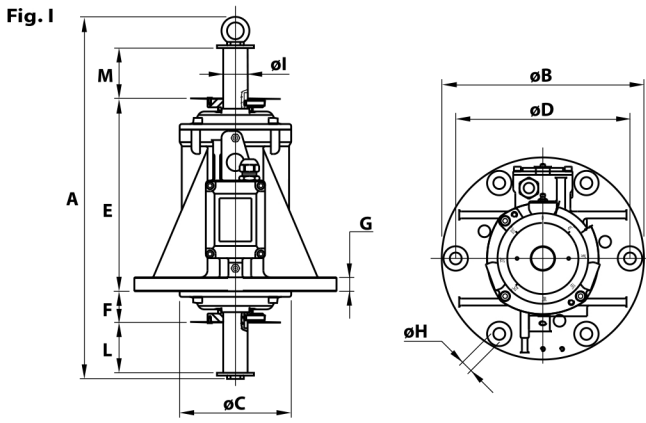

Dimensional specifications (mm)

I <sub>A</sub> /I <sub>N</sub>		Type	Fig.	A	øB	øC	øD	Holes øH	N°	E	F	G	øI	L	M	Cable entry thread
50 Hz	60 Hz															
3.76	4.50	MVB 1510/15	I	476	290	171	250	17	6	278	46	20	35	71	71	M25x1,5
5.60	5.81	MVB 2500/15	I	587	350	224	305	21	6	294	54	27	40	71	71	M25x1,5
4.48	4.18	MVB 4500/15	I	664	400	240	355	23.5	6	340	70	30	52	75	75	M25x1,5
6.19	6.73	MVB 7000/15	I	737	508	314	438	25	8	387	87	34	52	79	79	M25x1,5

Each C type weight group (in twos) is adjustable by phase shifting one in respect to the other. Each D type weight group (lamellars) is adjustable by removing one or more lamellar elements.

**Weight adjustment:** the weights at the two ends of the shaft can be staggered as required, with reference to the graduated discs on the shaft itself.

Type "C"

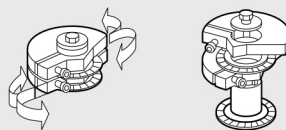

Infinitely adjustable centrifugal force

Type "D"

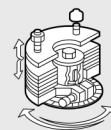

Centrifugal force adjustable from max. to min. by removing the lamellar weights.